

SAFC Split Bearing Solutions

NEW

SAFC Product Line

The Cooper pedestals have bolt hole center distances and base to bearing centerline heights that conform to industry standard SAF dimensions.

Cooper SAFC products are designed to replace common SAF 225 and 15 Series units using adaptor sleeves.

The Cooper SAFC compatible pedestal is available for bearings with shaft sizes from $1\frac{15}{16}$ " (SAFC 511) to $4\frac{7}{16}$ " (SAFC 526).

The pedestals use standard Cooper 01E and 02 Series bearings and cartridges. This makes possible the use of the comprehensive range of Cooper sealing options suitable for almost any application.

The seals remain concentric to the shaft under misalignment conditions and will retain lubricant and keep out foreign particles.

Two and four bolt configurations using 01E Medium Duty and 02 Heavy Duty bearings are available depending on shaft size.

The use of standard Cooper bearings and cartridges will cause the footprint area and total housing height to differ from compatible SAF housings.

Pedestals are made from ductile iron. Temperature and vibration mounting points may be specified.

Pedestal Loads

The maximum safe radial load for a pedestal casting is based on the bearing static rating C_{OR} . Up to 85% of the full C_{OR} rating can be applied if the angle of the load falls within the shaded area of the diagram shown.

If the load falls outside the shaded area or is greater than 85% of C_{OR} , please consult our technical department.

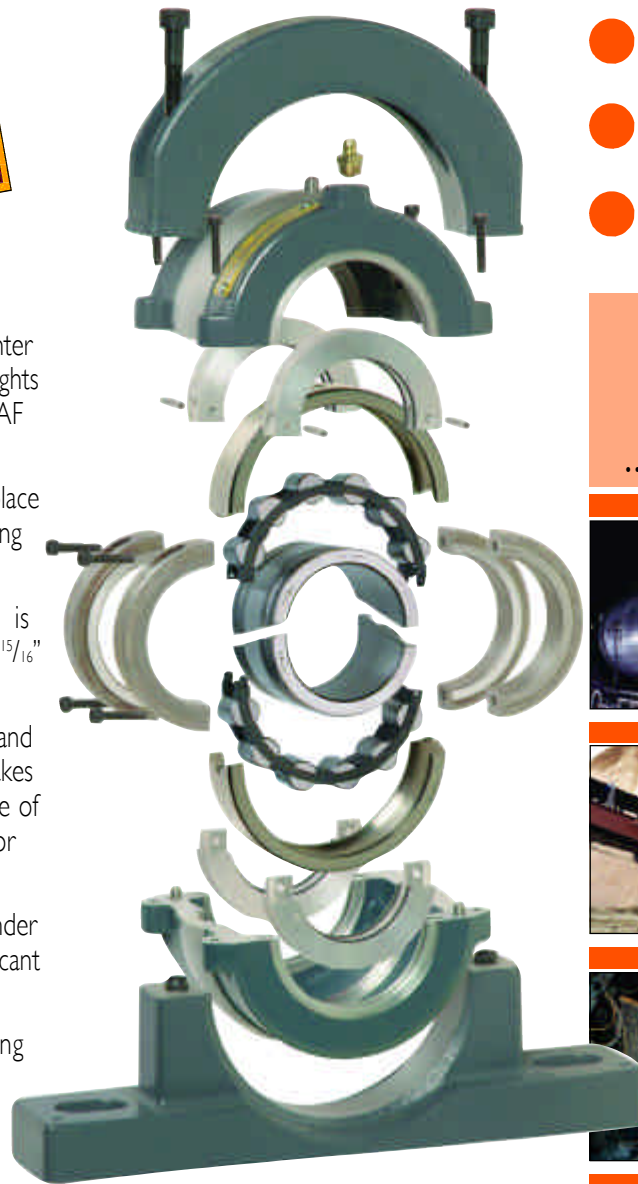

- Replaces Standard SAF Housings
- Easier and More Cost Effective Maintenance
- Superior Sealing

COMPATIBILITY and COMPETITIVE ADVANTAGE
...in these Industries...
...with Proven Solutions.

CEMENT & AGGREGATE INDUSTRIES



CONVEYORS AND MATERIALS HANDLING



FANS AND AIR MOVEMENT



MINE WINDERS AND CONVEYORS



PETRO-CHEMICAL INDUSTRY



When considering suitability of pedestal castings, the resultant effective radial load must be used. The effective radial load is the resultant of net loads and appropriate dynamic factors, excluding speed and life factors.

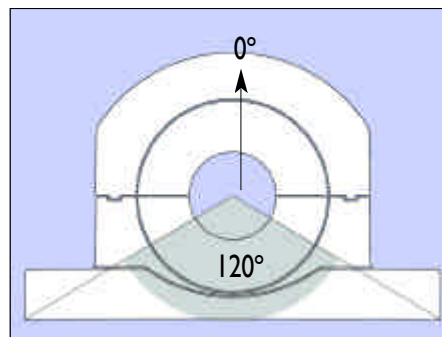

COOPER
A Supplier of Competitive Advantage

THE NEW COOPER SAF PRODUCT LINE

SAFC 2 BOLT PEDESTAL

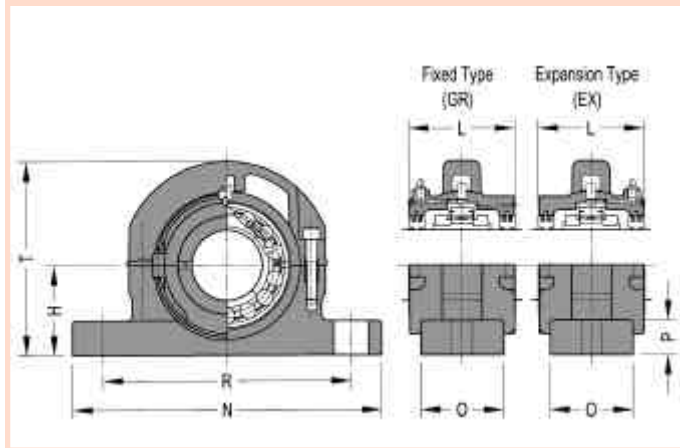

SAFC 4 BOLT PEDESTAL

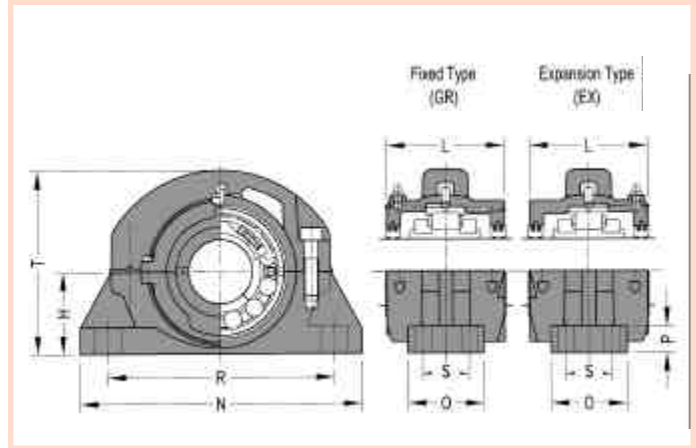

TECHNICAL SPECIFICATIONS

Shaft Size	Complete Assembly	Additional Bearing Sizes	H	R		S	Bolt Size	L	N	O	P	T
				Min	Max							
1 ⁵ / ₁₆ "	01EBC SAFC511 115 AT	1 ¹ / ₁₆ ", 1 ³ / ₄ ", 2" 45mm, 50mm	2 ³ / ₄ "	7 ³ / ₈ "	7 ⁷ / ₈ "	-	2 x 5/8"	3 ¹³ / ₁₆ "	9 ⁵ / ₈ "	2 ³ / ₄ "	7 ⁷ / ₈ "	6 ¹ / ₈ "
2 ³ / ₁₆ "	01EBC SAFC513 203 AT	2 ¹ / ₄ ", 2 ⁷ / ₁₆ ", 2 ¹ / ₂ ", 60mm, 65mm	3"	8 ¹ / ₈ "	9 ¹ / ₂ "	-	2 x 5/8"	4 ¹ / ₁₆ "	11"	3 ¹ / ₈ "	1"	7"
2 ⁷ / ₁₆ "	01EBC SAFC515 207 AT	2 ³ / ₁₆ ", 2 ¹ / ₄ ", 2 ¹ / ₂ ", 60mm, 65mm	3 ¹ / ₄ "	8 ⁵ / ₈ "	9 ⁵ / ₈ "	-	2 x 5/8"	4 ¹ / ₁₆ "	11 ¹ / ₄ "	3 ¹ / ₈ "	1 ¹ / ₈ "	7 ¹ / ₄ "
2 ¹ / ₁₆ "	01EBC SAFC516 211 AT	2 ³ / ₄ ", 2 ¹⁵ / ₁₆ ", 3", 70mm, 75mm	3 ¹ / ₂ "	9 ⁵ / ₈ "	11"	-	2 x 3/4"	4 ¹ / ₂ "	13"	3 ¹ / ₂ "	1 ¹ / ₄ "	8"
2 ¹⁵ / ₁₆ "	01EBC SAFC517 215 AT	2 ¹ / ₁₆ ", 2 ³ / ₄ ", 3", 70mm, 75mm	3 ³ / ₄ "	9 ⁷ / ₈ "	11"	-	2 x 3/4"	4 ¹ / ₂ "	13"	3 ¹ / ₂ "	1 ¹ / ₂ "	8 ¹ / ₄ "
2 ¹⁵ / ₁₆ "	02BC FSAFC517 215 AT	2 ¹ / ₁₆ ", 2 ³ / ₄ ", 3", 70mm, 75mm	3 ³ / ₄ "	9 ⁷ / ₈ "	11"	2 ¹ / ₈ "	4 x 5/8"	5 ¹ / ₂ "	13"	3 ¹ / ₂ "	1 ¹ / ₄ "	8 ¹ / ₂ "
3 ³ / ₁₆ "	01EBC SAFC518 303 AT	3 ¹ / ₄ ", 3 ⁷ / ₁₆ ", 3 ¹ / ₂ ", 80mm, 85mm, 90mm	4"	10 ³ / ₈ "	11 ⁵ / ₈ "	-	2 x 3/4"	5 ⁵ / ₁₆ "	13 ⁵ / ₈ "	3 ⁷ / ₈ "	1 ¹ / ₄ "	9 ¹ / ₂ "
3 ⁷ / ₁₆ "	01EBC SAFC520 307 AT	3 ³ / ₁₆ ", 3 ¹ / ₄ ", 3 ¹ / ₂ ", 80mm, 85mm, 90mm	4 ¹ / ₂ "	11 ⁵ / ₈ "	13 ¹ / ₈ "	-	2 x 7/8"	5 ⁵ / ₁₆ "	15 ¹ / ₄ "	4 ³ / ₈ "	1 ³ / ₄ "	10"
3 ⁷ / ₁₆ "	02BC FSAFC520 307 AT	3 ³ / ₁₆ ", 3 ¹ / ₄ ", 3 ¹ / ₂ ", 80mm, 85mm, 90mm	4 ¹ / ₂ "	11 ⁵ / ₈ "	13 ¹ / ₈ "	2 ³ / ₈ "	4 x 3/4"	6 ¹ / ₁₆ "	15 ¹ / ₄ "	4 ³ / ₈ "	1 ³ / ₄ "	10 ¹ / ₄ "
3 ¹⁵ / ₁₆ "	02BC SAFC522 315 AT	3 ¹ / ₁₆ ", 3 ³ / ₄ ", 4", 100mm, 105mm	4 ¹⁵ / ₁₆ "	12 ⁵ / ₈ "	14 ¹ / ₂ "	2 ³ / ₄ "	4 x 3/4"	5 ³ / ₄ "	16 ¹ / ₂ "	4 ³ / ₄ "	2"	11 ⁵ / ₈ "
4 ⁷ / ₁₆ "	02BC SAFC526 407 AT	4 ³ / ₁₆ ", 4 ¹ / ₂ ", 110mm, 115mm	6"	14 ⁵ / ₈ "	16"	3 ¹ / ₄ "	4 x 3/4"	6 ³ / ₈ "	18 ³ / ₈ "	5 ¹ / ₈ "	2 ³ / ₈ "	14 ¹ / ₄ "

Conversion from solid bearings to Cooper split roller bearings is easy.

The SAF compatible pedestal range offers the advantages of quick access, ease of change and low maintenance cost benefits of Cooper split bearing technology to both OEM's and end users.

The Cooper Split Roller Bearing Corp.

5365 Robin Hood Road, Suite B,

Norfolk, VA 23513, USA

Telephone 757 460 0925.

Fax 757 464 3067.

www.CooperBearings.com

COOPER[®]

A Supplier of Competitive Advantage

TOTALLY SPLIT TO THE SHAFT ROLLER BEARINGS