

Rex[®] Roller Bearings

Rex[®] 5000 Series
Premium Type E Mounted Roller Bearing



Rexnord
|||||

Get Your Bearings and Stay on Track

Rex® 5000 Series Premium Type E Mounted Roller Bearings help your equipment stay on track. The spherical bearing design accommodates continual misalignment. The two steel locking collars provide increased clamping force. All units are preassembled, preadjusted, greased, sealed and ready to install.

The following additional features make the Rex 5000 Series the premium choice for quality and performance:

- Threaded cover and microlock design allows bearing clearance adjustment; our off-the-shelf units meet special requirements such as temperature and speed
- Case hardened (carburized) inner ring resists fracturing, even under heavy loads
- Available in all housing styles, and with choice of Z, K, M seals or auxiliary caps
- Two-piece outer ring design allows unrestricted flow of grease to the bearing rolling elements
- High roller contact angle and roller spacing accommodates high thrust and combined loads
- 1.5° of misalignment in all directions, a total of 3°



Bearing the Weight of Your Load

The Rex® 5000 Series Premium Type E Mounted Roller Bearing is offered in a variety of collar types.

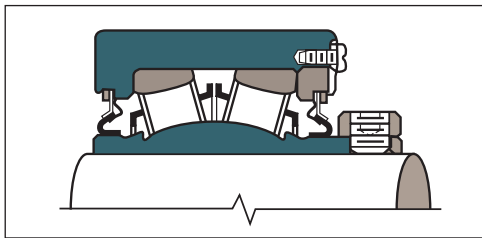

2000 Series Single Set Collar

- Normal-duty
- Simplest installation
- Most economical

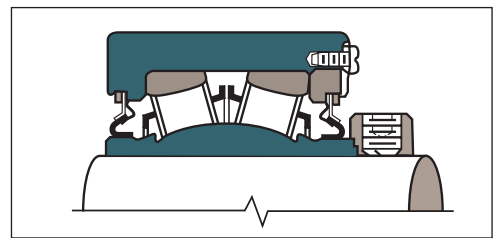

3000 Series Twist Lock™ Eccentric Locking Collar

- Medium-duty
- Additional shaft holding power
- Accommodates undersized shafting
- Economical

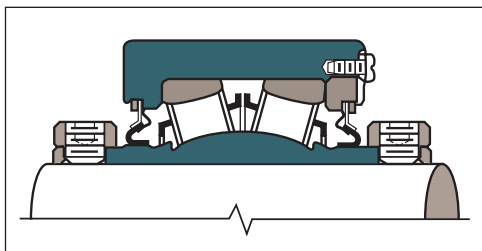

5000 Series Double Set Collar

- Heavy-duty
- Increased shaft holding power and stability
- Moderate cost

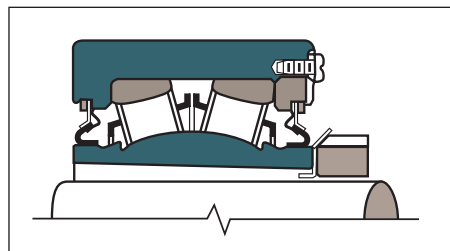

9000 Series Adapter Sleeve

- Extra-heavy-duty
- Full bore contact for maximum shaft holding power, concentricity, and running accuracy
- Accommodates undersized shafting

Bearing Down on Your Application Needs

Interchangeable Seals

Rex 5000 Series Premium Type E Mounted Roller Bearings have three interchangeable seals to meet a wide range of application requirements.

- Field interchangeability without bearing disassembly
- Operate on hardened and ground inner ring extension
- Cannot be forced out during relubrication
- Viton M Seal available for high temperature and chemical resistant applications

The following seal types are designed to fit your application needs.

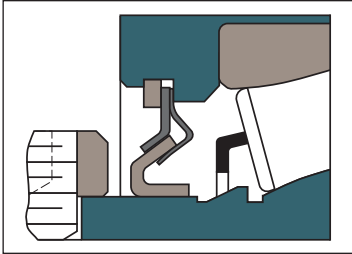

Z Seal

- No frictional drag – generates no heat
- No speed limitations
- All metal – no temperature limitations

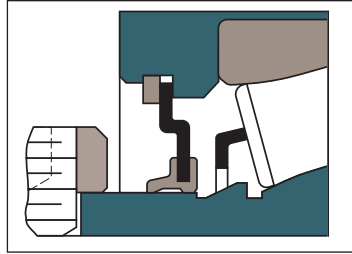

K Seal

- Protects against contaminants
- Handles high speeds
- Less drag and heat generation than heavy contact seals

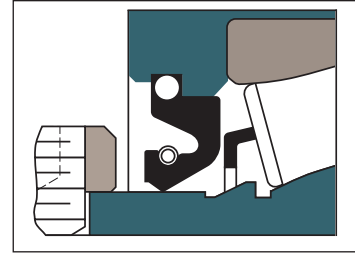

M Seal

- Protects against liquids and grit
- Spring-loaded lip assures constant contact – even during misalignment
- Molded-in garter spring retains seal in housing
- Seals in lubricant on horizontal and vertical shafts
- Available in viton material MA2207V

Auxiliary Caps – For Severe Applications

All caps are made from cast iron and are securely bolted to the housing. They allow for dynamic misalignment up to 2° included angle.

- The caps are self-cleaning. As clean grease is purged from the bearing to the cap, old grease is cleaned away from the primary lip seal. The old grease is then purged from the cap when fresh grease is pumped into the cap fitting.
- Seals against liquids, gritty contaminants
- Protects primary seal against physical damage
- Available open or closed end
 - A Prefix AMA2207 = 2 Open Caps
 - B Prefix BMA2207 = 1 Open (Housing Side) & 1 Closed
 - A Suffix MA2207A = 1 Open (Cover Side)
 - B Suffix MA2207B = 1 Closed (Cover Side)
 - C Suffix MA2207C = Closed End Cap (Housing Side)

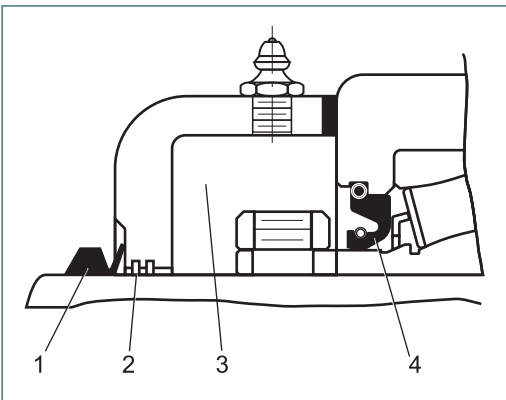
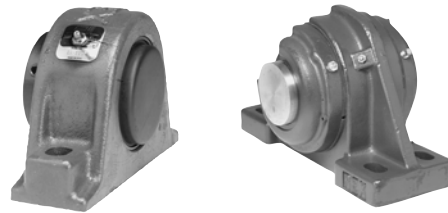

The Four Point Protection Plan

The Auxiliary Cap Four Point Protection Plan is designed to protect against contamination. For maximum protection, be sure to specify heavy contact “M” seals and auxiliary end caps.

The following components ensure that auxiliary caps used on Rex 5000 Series Premium Type E Mounted Roller Bearings provide premium protection:

1. Molded rubber V-ring seal is press-fit on shaft and rotates with it, prevents fine dirt and moisture from entering, so there is no wear on the shaft.
2. Machined multi-grooved labyrinth seal and rugged cast iron cap provide physical protection to primary bearing seal.
3. Large cavity traps contaminants and moisture. The cavity can be filled with grease to provide continuous purging.
4. The heavy contact “M” seal provides the final line of defense. It retains grease and prevents contamination from entering and damaging the bearings.

Integral Self-Alignment

Rex® Roller Bearings represent the continuation of 90 years of bearing technology and experience built upon the original Shafer design, consisting of: an inner race which forms a segment of a sphere; rollers shaped concave to run on the spherical surfaces of the inner and outer races; spherical outer races to contact the rollers. This design allows the inner race to misalign freely in any direction up to $1\frac{1}{2}^\circ$ from center, $\frac{5}{16}$ " per foot of shaft length.

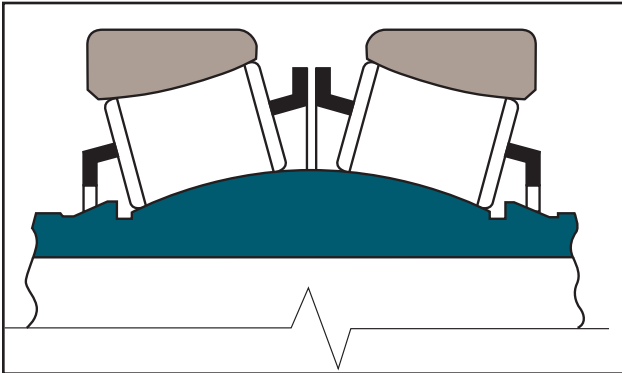

The rollers are aligned by the retainers and the outer races, so despite misalignment the roller load is always equally distributed. This prevents high edge load stresses on the rollers, which in turn means that **it is not necessary to derate Rex Bearings for misalignment conditions.**

By design, Rex Bearings accept both radial and thrust loads under static, oscillatory, or dynamic conditions. The load is taken on the roller raceways, not the roller ends. This means that when thrust loaded up to their allowable limit, **Rex Bearings do not exhibit roller end wear.**

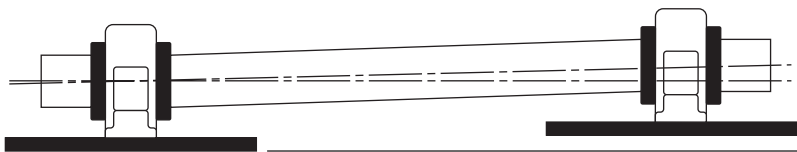

Static Misalignment
Bases Not Level

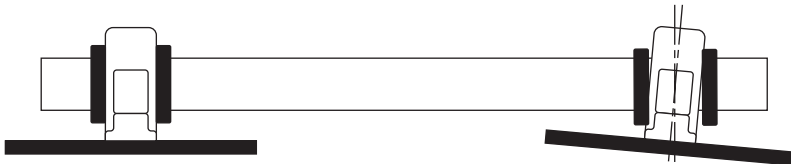

Bases Not Parallel

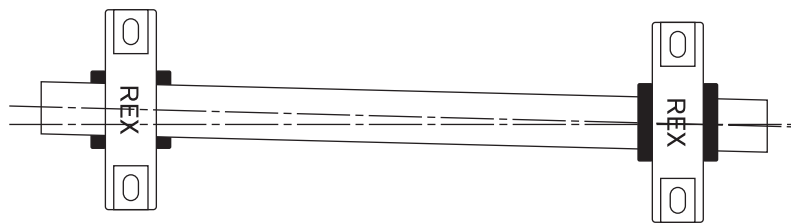

Bearings Have Horizontal Misalignment

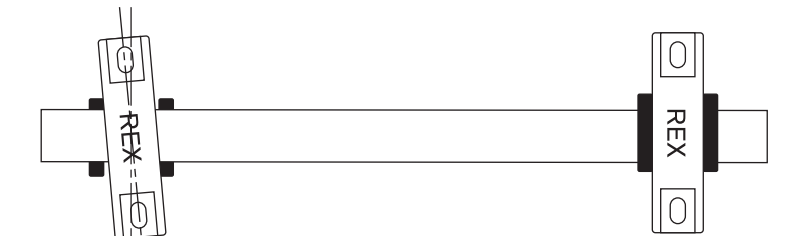

Bolts on Left Bearing are Vertically Misaligned

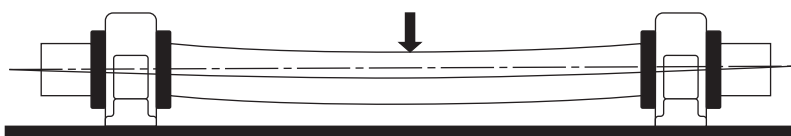

Dynamic Misalignment
Bent Shaft or Shaft Deflection from Load

Roller Load Distribution

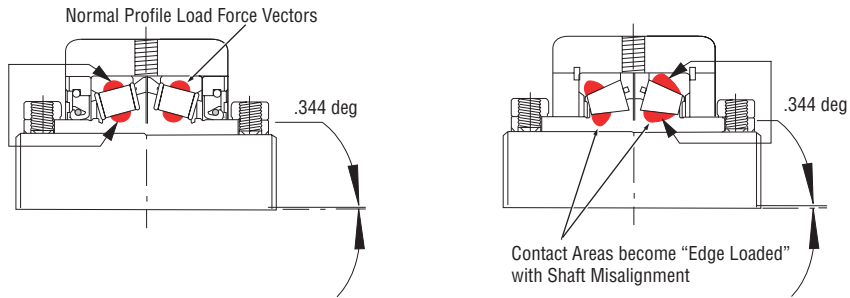

Rex Bearings

When misaligned-load remains even distributed

Tapered Bearings

When misaligned-roller edge loading occurs

Percent of Theoretical Life

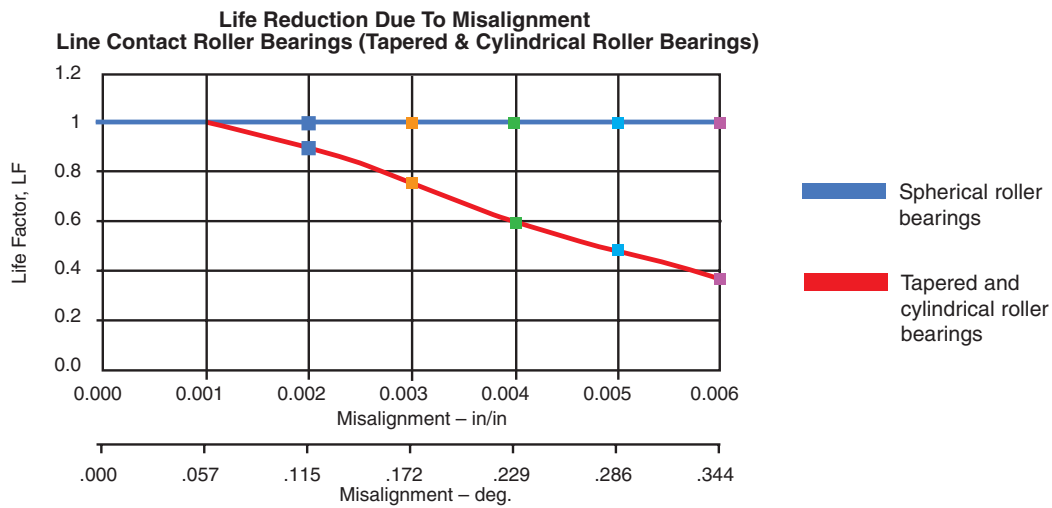

Rex 5000 Series Bearings=Longer Life

% of Theoretical Life Based on 36 inch bearing centers			
Degree of Misalignment	Off-set in inches	Spherical Roller	Tapered & Cylindrical Roller
0.115	0.072	100.00%	90.00%
0.172	0.108	100.00%	78.00%
0.229	0.144	100.00%	60.00%
0.286	0.180	100.00%	48.00%
0.344	0.216	100.00%	40.00%

Ref. STLE Life Factors for Rolling Bearings, Page 158, 1992 Edition, Kiblawi (1985)
It is not necessary to derate Rex 5000 Series Bearings for misalignment.

Life reduction due to misalignment for tapered and cylindrical roller bearings: 40% of the Theoretical L_{10} Life at .344°

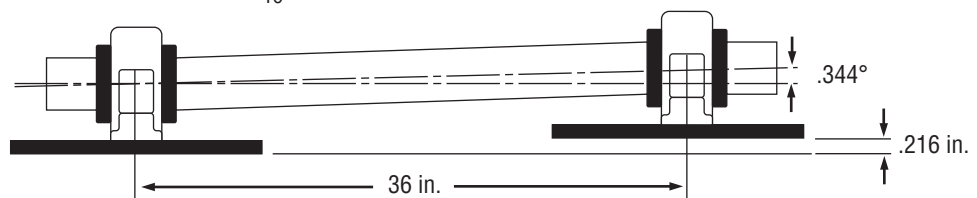

As referenced on right, 36" centers equals .216" off set. .216" equates to 40% of the Theoretical L_{10} Life.



Ordering Information

ZEP Pillow Blocks

Heavy-Duty
5000 Series
Double Set Collar

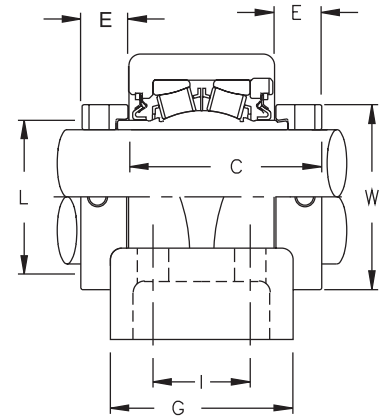
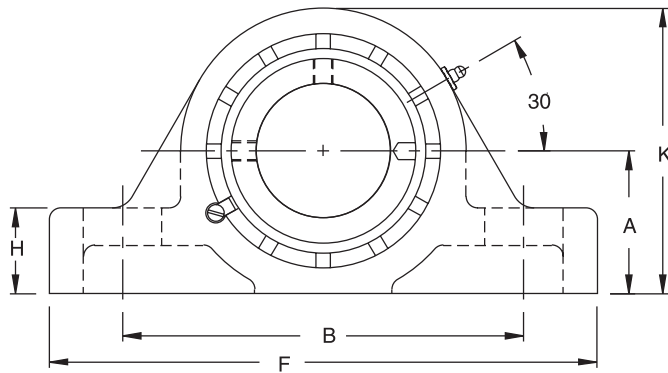
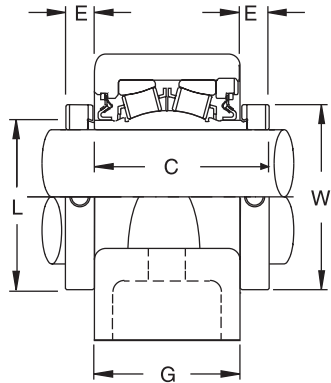

Shaft Size Inches	Complete Block Number	Typical Interchange	Size Code	Dimensions in Inches											Bolts Req'd.		Complete Block Net Wt. Lbs.		
				A	B		C	E	F	G	H	I	K	L	W	No.		Size	
					Min.	Max.													
1 7/16	ZEP-5107	P2B-E107R	4	1 7/8	4 11/16	6	3 9/16	11/16	7 3/8	2 3/16	1 1/8	...	3 11/16	1 3/4	2 5/16	2	1/2	6.9	
1 1/2	ZEP-5108	P2B-E108R	5	2 1/8	5 1/4	6 1/2	3 13/16	11/16	7 7/8	2 7/16	1 1/4	...	4 3/16	2 1/32	2 5/8	2	1/2	10.8	
1 11/16	ZEP-5111	P2B-E111R																10.5	
1 15/16	ZEP-5115	P2B-E115R	6	2 1/4	6	7 1/4	3 13/16	11/16	8 7/8	2 7/16	1 5/16	...	4 7/16	2 5/16	2 15/16	2	5/8	12.1	
2 3/16	ZEP-5203	P2B-E203R	7	2 1/2	6 1/2	8	4 1/8	25/32	9 5/8	2 9/16	1 1/2	...	4 15/16	2 5/8	3 1/4	2	5/8	15.9	
2 7/16	ZEP-5207	P2B-E207R	8	2 3/4	6 7/8	8 3/4	4 3/8	7/8	10 1/2	2 5/8	1 5/8	...	5 7/16	3	3 9/16	2	5/8	19.3	
2 7/16	ZEP-5207-F	P4B-E207R			8 1/4					3 1/2			1 7/8			5 1/2	4	5/8	19.3
2 11/16	ZEP-5211	P2B-E211R	9	3 1/8	7 13/16	9 3/4	4 7/8	13/16	12	3 3/16	1 7/8	...	6 1/4	3 3/8	4 1/16	2	3/4	31.3	
2 11/16	ZEP-5211-F	P4B-E211R			9 1/8	9 7/8				4						2 1/8	5/8	30.8	
2 15/16	ZEP-5215	P2B-E215R			7 13/16	9 3/4				3 3/16						...	2	3/4	30
2 15/16	ZEP-5215-F	P4B-E215R			9 1/8	9 7/8				4						2 1/8	5/8	29.6	
3 3/16	ZEP-5303	P2B-E303R	10	3 3/4	9 1/4	11 5/16	5 5/16	15/16	14	3 7/16	2 1/4	...	7 3/8	3 31/32	4 15/16	2	7/8	47.1	
3 3/16	ZEP-5303-F	P4B-E303R			10 9/16	11 7/16				4 1/2			2 3/8			7 1/2	4	3/4	48
3 7/16	ZEP-5307	P2B-E307R			9 1/4	11 5/16				3 7/16			...			7 3/8	2	7/8	44.7
3 7/16	ZEP-5307-F	P4B-E307R			10 9/16	11 7/16				4 1/2			2 3/8			7 1/2	4	3/4	45.2
3 11/16	ZEP-5311-F	-	11	4 1/4	12	13	6 1/4	1 1/16	15 1/4	4 1/2	2 5/8	2 1/4	8 5/8	4 9/16	5 5/8	4	3/4	66	
3 15/16	ZEP-5315-F	P4B-E315R																55	
4	ZEP-5400-F	P4B-E400R																65	
4 3/16	ZEP-5403F-F	-	12	4 3/4	12 7/8	14 1/8	6 1/4	1	16 1/2	4 5/8	2 3/4	2 1/2	9 3/8	5 1/32	6 3/16	4	3/4	81	
4 7/16	ZEP-5407Y-F	P4B-E407R																78	
4 1/2	ZEP-5408Y-F	P4B-E408R																76	
4 15/16	ZEP-5415-F	P4B-E415R																150	
5	ZEP-5500-F	P4B-E500R	13	5 1/2	14 7/8	16 1/8	7 7/8	1 3/16	18 1/2	5 9/16	3	2 3/4	11 1/8	5 3/4	7 1/16	4	7/8	147	

4-bolt block - Use suffix F
Bore Size-Nominal Shaft Size +.001 - .000
Seals - To specify K or M seal, replace "Z" in model number with "K" or "M"
Auxiliary Caps - Available in all size codes



Ordering Information

ZEF Flange Blocks

Heavy-Duty
5000 Series
Double Set Collar

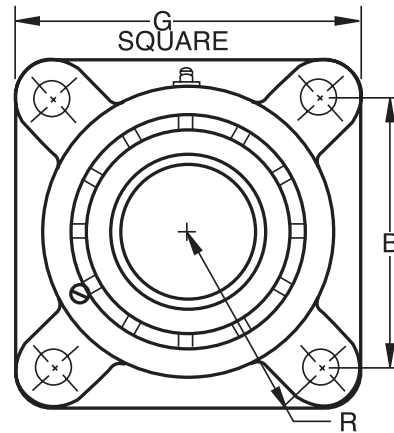
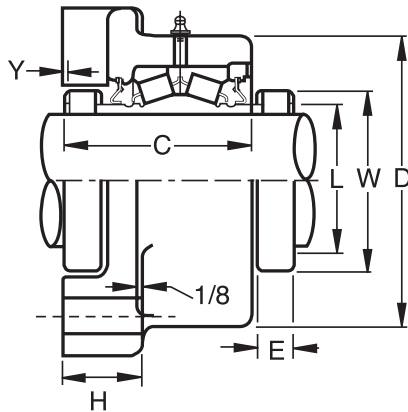

Shaft Size Inches	Complete Block Number	Typical Interchange	Size Code	Dimensions in Inches										Bolts Req'd.		Complete Block Net Wt. Lbs.
				B	C	D	E	G	H	L	R	W	Y	No.	Size	
				1 7/16	ZEF-5107	F4B-E-107R	4	3 1/2	3 9/16	3 11/16	11/16	4 5/8	1 3/8	1 3/4	2 15/32	
1 1/2	ZEF-5108	F4B-E-108R	5	4 1/8	3 13/16	4 1/4	11/16	5 3/8	1 7/16	2 1/32	2 59/64	2 5/8	1/8	4	1/2	9.2
1 11/16	ZEF-5111	F4B-E-111R		10.6												
1 15/16	ZEF-5115	F4B-E-115R	6	4 3/8	3 13/16	4 1/4	11/16	5 3/8	1 1/2	2 5/16	3 3/32	2 15/16	1/8	4	1/2	11.6
2 3/16	ZEF-5203	F4B-E-203R	7	4 7/8	4 1/8	5	25/32	6 1/4	1 1/2	2 5/8	3 29/64	3 1/4	1/8	4	5/8	15.2
2 7/16	ZEF-5207	F4B-E-207R	8	5 3/8	4 3/8	5 1/2	7/8	6 7/8	1 11/16	2 29/32	3 51/64	3 9/16	3/16	4	5/8	18.3
2 11/16	ZEF-5211	F4B-E-211R	9	6	4 7/8	6 1/2	13/16	7 3/4	1 13/16	3 3/8	4 1/4	4 1/16	3/16	4	3/4	30.2
2 15/16	ZEF-5215	F4B-E-215R		28.7												
3 3/16	ZEF-5303	F4B-E-303R	10	7	5 5/16	7 3/8	15/16	9 1/4	1 15/16	3 31/32	4 61/64	4 15/16	1/4	4	3/4	44.6
3 7/16	ZEF-5307	F4B-E-307R		42.7												
3 11/16	ZEF-5311	-	11	7 3/4	6 1/4	8 7/8	1 1/16	10 1/4	2 3/16	4 9/16	5 31/64	5 5/8	1/4	4	7/8	73.5
3 15/16	ZEF-5315	F4B-E-315R		69.0												
4	ZEF-5400	F4B-E-400R		71.5												

Bore Size=Nominal Shaft Size +.001 -.000

Seals - To specify K or M seal, replace "Z" in model number with "K" or "M"

Auxiliary Caps - Available in all size codes



The Power of Rexnord™

World Class Customer Service

For over 100 years the dedicated people of Rexnord have delivered excellence in quality and service to our customers around the globe. Rexnord is a trusted name when it comes to providing skillfully engineered products that improve productivity and efficiency for industrial applications worldwide. We are committed to exceeding customer expectations in every area of our business: product design, application engineering, operations and customer service.

Because of our customer focus, we are able to more thoroughly understand the needs of your business and have the resources available to work closely with you to reduce maintenance costs, eliminate redundant inventories and prevent equipment down time.

Rexnord represents the most comprehensive portfolio of power transmission and conveying components in the world with the brands you know and trust.

WORLDWIDE CUSTOMER SERVICE

AUSTRALIA

Rexnord Australia Pty. Ltd.
Picton, New South Wales
Phone: 61.2.4677.3811
Fax: 61.2.4677.3812

BRAZIL

Rexnord Correntes Ltda.
Sao Leopoldo - RS
Phone: 55.51.579.8022
Fax: 55.51.579.8029

CANADA

Rexnord Canada Ltd.
Scarborough, Ontario
Phone: 1.416.297.6868
Fax: 1.416.297.6873

CHINA

Rexnord China
Shanghai, China
Phone: 86.21.62701942
Fax: 86.21.62701943

EUROPE

Rexnord NV/SA
Mechelen, Belgium
Phone: 32.70.22.33.66
Fax: 32.70.22.33.67

Rexnord Marbett, S.r.L.
Correggio (RE), Italy
Phone: 39.0522.639333
Fax: 39.0522.637778

Rexnord FlatTop Europe b.v.
s-Gravenzande, Netherlands
Phone: 31.174.445111
Fax: 31.174.445222

LATIN AMERICA

Rexnord International, Inc.
Milwaukee, Wisconsin
Phone: 1.414.643.3000
Fax: 1.414.643.3222

MEXICO

Rexnord S.A. de C.V.
Queretaro, Qro.
Phone: 52.442.218.5000
Fax: 52.442.218.1090

SINGAPORE

Rexnord International, Inc.
Singapore City, Singapore
Phone: 65.6338.5622
Fax: 65.6338.5422

UNITED STATES

Eastern Service Center
Atlanta, Georgia
Phone: 1.770.431.7200
Fax: 1.770.431.7299

Central Service Center
Grove City, Ohio
Phone: 1.614.675.1800
Fax: 1.614.675.1898

Southern Service Center
Arlington, Texas
Phone: 1.817.385.2800
Fax: 1.817.385.2873



Rexnord Corporate Headquarters
4701 West Greenfield Avenue
Milwaukee, WI 53214
Phone: 1.414.643.3000 Fax: 1.414.643.3078
or Visit us on-line at www.rexnord.com